

MINIMUM STANDARD
SPECIFICATIONS
FOR
STREETS



City of Bryant, Arkansas
Revised April 2022

TABLE OF CONTENTS

Section	Title	Page
SECTION 1 - GENERAL PROVISIONS		
1.1	PURPOSE	1-1
1.2	JURISDICTION	1-1
1.3	APPLICABILITY	1-1
1.4	APPROVAL REQUIRED	1-1
1.5	AMENDMENTS	1-1
1.6	CONFLICTING REGULATIONS	1-1
SECTION 2 - GENERAL REQUIREMENTS		
2.1	PERMITS	2-1
2.2	PLANS AND SPECIFICATIONS	2-1
2.3	RESPONSIBILITY OF DEVELOPER/OWNER	2-1
2.4	ENGINEERING SERVICES	2-1
2.5	PLAN SUBMITTAL	2-2
2.6	OBSERVATION OF CONSTRUCTION BY THE CITY OF BRYANT	2-2
2.7	ACCEPTANCE BY THE CITY OF BRYANT	2-2
2.8	NEED FOR A TRAFFIC STUDY	2-2
2.9	DAMAGE TO EXISTING STREETS	2-2
2.10	DEFINITIONS	2-2
2.11	REFERENCES	2-3
SECTION 3 -DESIGN DATA AND PLAN SUBMISSION		
3.1	GENERAL	3-1
3.2	DESIGN REPORT	3-1
3.3	HORIZONTAL AND VERTICAL DATUM	3-1
3.4	PLANS	3-1
3.5	SPECIFICATIONS	3-2

Section	Title	Page
3.6	AS-BUILT PLANS	3-2
SECTION 4 - STREET DESIGN PRINCIPLES		
4.1	GENERAL	4-1
4.2	ALIGNMENT	4-1
4.3	INTERSECTIONS	4-1
4.4	RIGHT OF WAY WIDTHS AND CROSS SECTIONS	4-1
4.5	MINIMUM AND MAXIMUM GRADES	4-3
4.6	SIGHT DISTANCE AND DESIGN SPEEDS	4-3
4.7	DEAD END STREETS/CUL-DE-SACS	4-3
4.8	PAVEMENT MARKINGS	4-4
4.9	TRAFFIC SIGNS	4-4
4.10	ALLEYS	4-4
4.11	STREET LIGHTS	4-4
4.12	ACCESS MANAGEMENT	4-5
SECTION 5 - PAVEMENT DESIGN		
5.1	PAVEMENT TYPES	5-1
5.2	PAVEMENT MATERIALS AND CONSTRUCTION	5-1
5.3	GEOTECHNICAL REQUIREMENTS	5-1
5.4	PAVEMENT DESIGN REQUIREMENTS	5-1
5.5	SUBGRADE MATERIAL	5-2
5.6	BASE COURSE	5-3
5.7	SURFACE COURSE	5-3
5.8	CURB AND GUTTER	5-3
5.9	SUBSURFACE DRAINAGE	5-4
5.10	ONE-HALF STREET IMPROVEMENTS	5-4
SECTION 6 - UTILITIES AND UTILITY CROSSINGS		
6.1	GENERAL	6-1
6.2	FRANCHISED UTILITY LINES	6-2
6.3	WATER, WASTEWATER, AND STORM DRAIN LINES	6-2
6.4	BORING AND JACKING	6-2

Section	Title	Page
6.5	PAVEMENT CUTS- EXISTING STREETS	6-3
6.6	DRAINAGE AND/OR UTILITY CUT BACKFILL ON STREET UNDER CONST ..	6-3
SECTION 7 – STORM DRAINAGE AND DRAINAGE FACILITIES		
7.1	GENERAL	7-1
7.2	STORM DRAIN MATERIALS	7-1
7.3	BEDDING MATERIAL	7-1
7.4	DROP INLETS AND JUNCTION BOXES.....	7-1
7.5	BRIDGES	7-2
SECTION 8 - QUALITY CONTROL TESTING AND INSPECTIONS		
8.1	GENERAL	8-1
8.2	QUALITY CONTROL TESTING	8-1
8.3	SUBGRADE	8-2
8.4	BASE COURSE	8-3
SECTION 9 - EROSION CONTROL		
9.1	GENERAL	9-1
9.2	PERMITS REQUIRED	9-1
SECTION 10-SIDEWALKS		
10.1	GENERAL	10-1
10.2	MINIMUM THICKNESS AND REINFORCEMENT	10-1
10.3	MINIMUM WIDTH	10-1
10.4	CONTRACTION AND EXPANSION JOINTS	10-1
10.5	QUALITY CONTROL TESTING AND INSPECTION BY CITY OF BRYANT	10-1

APPENDIX

A	TYPICAL DETAILS
---	-----------------

SECTION 1
GENERAL PROVISIONS

PART 1.1 PURPOSE

- A. These regulations govern the design, construction and maintenance of streets, alleys and sidewalks which lie within the jurisdiction of the City of Bryant. These specifications are the minimum requirements and it is understood that more stringent requirements may be mandated by the Planning Commission, Development Review Committee, Bryant Street Department and/or Bryant Public Works with regard to a specific project.

PART 1.2 JURISDICTION

- A. These regulations shall be applicable to all lands within the City of Bryant and its planning area. The planning area shall be defined as all land lying within five miles of the corporate limits.

PART 1.3 APPLICABILITY

- A. All construction and development within the jurisdiction of the City of Bryant is subject to these regulations.

PART 1.4 APPROVAL REQUIRED

- A. All street designs are subject to the review and approval by the City of Bryant and/or their respective designee(s). Street improvements associated with private development shall receive Planning Commission approval prior to commencing construction.

PART 1.5 AMENDMENTS

- A. Amendments to these regulations shall be presented to the Bryant City Council for adoption.

PART 1.6 CONFLICTING REGULATIONS

- A. All city ordinances or parts of ordinances inconsistent or in conflict with these regulations are hereby repealed and amended to comply herewith by virtue of the ordinance adopting this regulation. In the event design and construction specifications prepared separately by a licensed professional engineer for improvements associated with private development conflict with these regulations, the more stringent requirement shall govern.

SECTION 2

GENERAL REQUIREMENTS

PART 2.1 PERMITS

- A. All permits required to accomplish the work shall be the responsibility of the Developer/Owner or Engineer of Record. Such permits may include but are not limited to permits for work within Arkansas Highway and Transportation Department right-of-way, railroad crossing permits, Arkansas Department of Environmental Quality permits, and Corps of Engineers permits.

PART 2.2 PLANS AND SPECIFICATIONS

- A. Detailed plans and specifications shall be required for all new streets, street extensions, and one-half street improvements. Plans and specifications shall be prepared by a licensed Professional Engineer (licensed in the State of Arkansas).
- B. Approval of the detailed plans and specifications by the City of Bryant does not constitute warranty of the plans and specifications and does not relieve the Engineer of Record of his professional responsibility in the design of the facilities or in the preparation of any engineering reports prepared in association with the project.
- C. The standard specifications for Highway Construction as promulgated by the Arkansas Highway and Transportation Department (AHTD), latest edition, and the Standard Drawings of the Arkansas State Highway and Transportation Department shall be the basis for the preparation of street plans and specifications and shall apply in all cases except where these Minimum Standard Specifications For Streets are in direct conflict with AHTD standards.

PART 2.3 RESPONSIBILITY OF DEVELOPER/OWNER

- A. The Developer/Owner shall be responsible for construction of streets, including all design, construction, quality control testing, and for all costs associated therewith.
- B. The Developer/Owner shall provide all engineering services required for planning, design, investigations, inspection, testing, and related activities necessary for street development, and shall be responsible for construction of street improvements in accordance with the design approved by the City of Bryant as satisfying the requirements of these regulations.
- C. The City of Bryant shall have the right of access to sites during the planning, design, and construction phases of street development. The Developer shall schedule all activities to provide the City with adequate notice and review time.

PART 2.4 ENGINEERING SERVICES

- A. All engineering services, including but not limited to, planning, design, investigations, inspection, and testing shall be under the supervision of a Professional Engineer licensed in the State of Arkansas.
- B. The design data, plans, specifications and related information shall bear the name of the Engineer of Record. The seal of the Engineer of Record shall be placed on each sheet of the plans along with his/her signature.
- C. Soils investigations, materials testing, and quality control testing shall be performed by a laboratory approved by the City of Bryant.

- D. Written certification by the Engineer of Record that materials and construction conform to the approved Plans and Specifications is required as stated in Section 3.6 of these specifications. Inspection and testing requirements are outlined in Section 8 of these specifications.

PART 2.5 PLAN SUBMITTAL

- A. Plans, specifications and all data submitted in conjunction with the plans and specifications shall constitute a complete design. Approval by the City of Bryant will not be issued until all requirements have been fulfilled. Approval of the plans and specifications shall remain in effect for one (1) year from the approval date. After that time a new set of plans and specifications shall be submitted and any regulations or rules promulgated between the time of the original submittal and the new submittal date shall be followed.
- B. All changes in the design or construction of a project or development, including all changes in the plans and/or specifications, shall be submitted to the City of Bryant for approval. The City of Bryant shall be notified immediately of all field changes in order that a timely approval may be issued.

PART 2.6 OBSERVATION OF CONSTRUCTION BY THE CITY OF BRYANT

- A. The observation of street construction by the City of Bryant will be limited to general observations of the project at various stages as outlined in Section 8 of these specifications. The City of Bryant reserves the right to observe the construction at all times.

PART 2.7 ACCEPTANCE BY THE CITY OF BRYANT

- A. After the Final Inspection and Acceptable Completion of the street construction, the Developer/Owner shall provide a Maintenance Warranty to the City of Bryant which guarantees the maintenance, repair, and/or reconstruction of the project in whole or in part for a period of 12 months (1 year) after the date of the Maintenance Warranty. The Maintenance Warranty shall be in the amount of 25 percent of the cost of construction of the improvements, but not less than \$50,000.
- B. Formal acceptance of the project by the City of Bryant will be made in writing after the posting of the Maintenance Warranty. The date of the formal acceptance shall be the same date as given in the Maintenance Warranty.

PART 2.8 NEED FOR A TRAFFIC STUDY

- A. A formal Traffic Study/Traffic Impact Analysis (firm shall be approved by the City of Bryant) will be required for any development proposal expected to generate 5,000 or more vehicle trips daily, as calculated using the most recent version of the Institute of Traffic Engineers (ITE) Trip Generation Manual, or any other generally accepted traffic engineering criteria. For a rezoning case, the trip generation of the proposed zoning must increase by 1,000 vehicle trips daily over the current zoning.

PART 2.9 DAMAGE TO EXISTING STREETS

- A. During construction of the property being developed, the Developer/Owner shall be responsible for damage to existing streets that are adjacent to the property being developed.
- B. All street repairs shall be subject to the review and approval of the City of Bryant.

PART 2.10 DEFINITIONS

- A. The following words, terms, and phrases, when used in this article, shall have the meanings ascribed to them in this section.

AASHTO - American Association of State Highway and Transportation Officials.

Acceptable Completion - This term shall mean substantial completion of the street construction as agreed upon by the City of Bryant and Engineer of Record.

ADEQ - Arkansas Department of Environmental Quality

AHTD - Arkansas Highway and Transportation Department

ASTM - American Society for Testing and Materials

City - The City of Bryant, Arkansas and its employees expressly authorized by the Mayor to accomplish the specified task.

Contractor - The licensed contracting company hired by the Developer/Owner to construct the street improvements.

Developer/Owner - The person, firm, partnership, corporation or other entity planning, constructing, altering or reconstructing a public street.

Engineer of Record - The Arkansas licensed Professional Engineer responsible for the design of the improvements, usually engaged by the Developer/Owner.

Final Inspection - The final inspection shall be the formal inspection of the street construction by the City of Bryant, the Engineer of Record, and the contractor, which results in a declaration of acceptable completion.

Formal Acceptance - Acceptance of the street construction in writing after a Maintenance Warranty has been submitted to and approved by the City of Bryant.

Maintenance Warranty - The security instrument which binds the Owner/Developer to a one (1) year responsibility for street construction, repairs and/or reconstruction in the event of street construction failure.

Street Construction - Where this or similar terms are used, it shall mean construction of the street, curb and gutter, drainage (whether on the street or not), sidewalks, and all other appurtenances normally associated with street construction and approved as part of the street plans, whether on-site or off-site.

Substantial Completion - The construction stage at which point all improvements and associated appurtenances have been fully constructed and are functional.

Traffic Impact Analysis - Study to assess the near term and long term effects of specific development activity on the roadway system in a comprehensive manner. Development activity may include rezoning, platting and development plan approvals.

PART 2.11 REFERENCES

- A. References to various materials, testing and construction such as AASHTO, ASTM, AHTD, etc. shall refer to the latest editions of the reference standard.

SECTION 3

DESIGN DATA AND PLAN SUBMISSION

PART 3.1 GENERAL

- A. The submittal shall be complete with all necessary information included for review of the project. The material required shall include, but not be limited to the plans, specifications, geotechnical report, and drainage report. The final review will be concurrent with the review of all public improvements including water, sewer and drainage as accomplished through the Development Review Committee and the Planning Commission.

PART 3.2 DESIGN REPORT

- A. The design report shall contain all information not normally shown on the plans or given in the specifications, including design calculations, results of soil borings, soil reports, soil test results, and any other data used in the development of the plans and specifications. The design report shall be made available upon request by the City of Bryant.
- B. Geotechnical information shall be submitted in accordance with Section 5 of these specifications.

PART 3.3 HORIZONTAL AND VERTICAL DATUM

- A. All street construction, including storm drainage facilities, shall be tied to the Arkansas State Plane Coordinate System, South Zone, using the North American Datum of 1983 (NAD83).
- B. Elevation of controlling points shall be based on USGS NAVD 88 datum.

PART 3.4 PLANS

- A. The plans shall be submitted on 24" x 36" sheets. No other size shall be permitted unless specifically approved by the City of Bryant. Three sets of plans, including one AutoCad compatible digital format copy and one pdf format copy, shall be required.
- B. Plans shall be submitted at the scale necessary to make the plans easily read and interpreted. Plans shall be on a scale of not less than 1" = 50'. The plans shall include, but not be limited to the following information:
 - 1. Street right-of-way, proposed and existing
 - 2. Existing and proposed utility and drainage easements
 - 3. Existing and proposed property lines
 - 4. Horizontal curve data
 - 5. Plan and profile data with street grades and elevations
 - 6. Centerline stationing
 - 7. Street names
 - 8. Location and size of existing and proposed utilities
 - 9. Intersection radii
 - 10. Soil boring locations
 - 11. Legend showing typical symbols used in the plans
 - 12. North arrow and scale
 - 13. Street and right of way dimensions
 - 14. Sidewalks and trails with dimensions
 - 15. Handicap access ramp locations
 - 16. Typical street cross sections
 - 17. Proposed and existing storm drainage facilities

- C. Street profiles shall be shown on a horizontal scale to match the layout with a vertical scale of not less than 1" = 5'. Information to be shown with the profiles shall include, but not be limited to:
 - 1. Existing ground elevations
 - 2. Vertical curve data
 - 3. Proposed and existing drainage and utility line crossings (size and location)
 - 4. Proposed finished grades at street centerline
 - 5. Cross sections at a maximum spacing of 50 feet if requested by the City of Bryant. Additional cross sections shall be where needed for clarification purposes.

- D. A typical street cross section for all classes of streets designed shall be included in the plans and shall show the following with associated dimensions:
 - 1. Pavement type, width and thickness including subgrade and base layers
 - 2. Dimensions from back of curb to back of curb
 - 3. Cross slope and crown
 - 4. Curb and gutter
 - 5. Existing and proposed grades
 - 6. Right of way width
 - 7. Sidewalks or trails. Include dimensions for locating behind back of curb
 - 8. Landscaping, if required

- E. Revisions to drawings shall show the nature of revisions and preparation date. Cloud revisions in plan and/or profile view(s).

PART 3.5 SPECIFICATIONS

- A. Technical specifications shall include material requirements and methods of construction, quality control requirements, sampling, and testing procedures and frequency as specified in other sections of these specifications.

PART 3.6 AS-BUILT PLANS

- A. As-Built plans shall depict an accurate account of the construction. Construction plans which are "rubber stamped" and submitted for the purpose of "As-Built" plans are not acceptable.

- B. Three sets of "As-Built" plans, including one AutoCad compatible digital format copy and one pdf format copy, shall be required along with the final costs associated with the street construction, and shall be due prior to the filing of the Final Plat. Engineer of Record shall certify in writing that all improvements meet the requirements of the approved construction drawings and City of Bryant Minimum Standard Specifications for Streets along with the "As-Built" plans.

SECTION 4

STREET DESIGN PRINCIPLES

PART 4.1 GENERAL

- A. The principles governing the design of streets shall conform to the requirements of these specifications, and to the latest editions of AHTD standard specifications, MUTCD, AASHTO - A policy on Geometric Design of Highway and Streets, and AASHTO - Guide for the Development of Bicycle Facilities, to the standards that may be referenced herein, and to appropriate City Ordinances.
- B. General criteria with regard to street classification shall be as stated in the City of Bryant Master Street Plan. The City of Bryant Public Works and/or Development Review Committee shall determine if a street classified as a "Collector" shall be constructed to the "Rural Collector" or "Industrial Collector" minimum standards.
- C. Streets within commercial areas (commercial zoning) shall be constructed to "Collector" minimum standards unless otherwise identified on the Master Street Plan as a Major Arterial or Minor Arterial.
- D. Storm drainage shall meet the requirements of the City of Bryant Storm Water Regulations. Valley gutters shall not be permitted.
- E. Landscaping shall meet the requirements of the City of Bryant Landscape Ordinance.

PART 4.2 ALIGNMENT

- A. The minimum curve radius for streets shall be as follows:
 - 1. Local 1 and 2/Residential Streets = 25 feet.
 - 2. Collector Streets = 35 feet.
 - 3. Arterial Streets = 50 feet.
- B. Street jogs with centerline offsets shall not be less than 125 feet.

PART 4.3 INTERSECTIONS

- A. Street intersections shall be as nearly at right angles as possible but not less than 75 degrees. Where street intersections are less than 90 degrees, the curb radius shall be increased as determined by City of Bryant Street Department, City of Bryant Public Works and/or the Development Review Committee.

PART 4.4 RIGHT OF WAY WIDTHS AND CROSS SECTIONS

- A. The City of Bryant may require, at their discretion, different lane configurations and buffer zones for all street classifications, depending on the need for medians, turn lanes, bike lanes, etc.
- B. Minor Arterial
 - 1. The minimum right of way width shall be 80 feet.
 - 2. The typical street cross section shall allow for four lanes.
 - 3. The minimum pavement width shall be 57 feet back to back of curb.
 - 4. Bike lanes with a minimum width of 5'-0" are required on both sides of the street.
 - 5. There are numerous cross section configurations depending on possible features including medians, center turn lanes, and bike lanes. The street cross section shall be as determined by the Development Review Committee and Planning Commission. The City of Bryant may require different traffic and bike lane configurations if turn lanes are required by the City of Bryant. The

City of Bryant may require additional pavement width to accommodate turn lanes.

6. Curb and gutter is required unless specific authorization to construct a paved shoulder and open ditches is granted by City of Bryant Street Department, City of Bryant Public Works, Development Review Committee, and/or City of Bryant Planning Commission. Width of paved shoulder (if allowed) and street cross section shall be as determined by City of Bryant Street Department and/or City of Bryant Public Works.
7. A sidewalk with a minimum width of 5 feet is required on both sides of the road.
8. At a minimum, cross section shall be in accordance with the typical street cross section detail included with these specifications.

C. Collector

1. The minimum right of way width shall be 60 feet.
2. The minimum pavement width shall be 40 feet back to back of curb.
3. Bike lanes with a minimum width of 6'-6" are required on both sides of the street.
4. Curb and gutter is required unless specific authorization to classify the road as a rural collector is granted by City of Bryant Street Department, City of Bryant Public Works and/or the Development Review Committee.
5. A sidewalk with a minimum width of 5 feet is required on both sides of the road.
6. A minimum 5'-0" buffer zone between the back of curb and the concrete sidewalk is required on both sides of the street.
7. At a minimum, cross section shall be in accordance with the typical street cross section detail included with these specifications.
8. The City of Bryant may require different traffic and bike lane configurations if turn lanes are required by the City of Bryant. The City of Bryant may require additional pavement width to accommodate turn lanes.

D. Rural Collector

1. The minimum right of way width shall be 80 feet.
2. The minimum pavement width shall be 40 feet from edge of shoulder to edge of shoulder.
3. Bike lanes with a minimum width of 6'-6" are required on both sides of the street.
4. Paved shoulders with a minimum width of 2 feet are required on both sides of the street.
5. Open ditches shall be provided on both sides of the street.
6. Curb and gutter is not required.
7. A sidewalk with a minimum width of 5 feet is required on both sides of the road.
8. A minimum 15'-0" buffer zone between the back of curb and the concrete sidewalk is required on both sides of the street.
9. At a minimum, cross section shall be in accordance with the typical street cross section detail included with these specifications.
10. The City of Bryant may require different traffic and bike lane configurations if turn lanes are required by the City of Bryant. The City of Bryant may require additional pavement width to accommodate turn lanes.

E. Industrial Collector

1. The minimum right of way width shall be 80 feet.
2. The minimum pavement width shall be 40 feet back to back of curb.
3. Bike lanes with a minimum width of 6'-6" are required on both sides of the street.
4. Curb and gutter is required unless specific authorization to classify the road as a rural collector is granted by City of Bryant Street Department, City of Bryant Public Works and/or the Development Review Committee.
5. A sidewalk with a minimum width of 5 feet is required on both sides of the road.
6. A minimum 15'-0" buffer zone between the back of curb and the concrete sidewalk is required on both sides of the street.
7. At a minimum, cross section shall be in accordance with the typical street cross section detail included with these specifications.

8. The City of Bryant may require different traffic and bike lane configurations if turn lanes are required by the City of Bryant. The City of Bryant may require additional pavement width to accommodate turn lanes.

F. Local 1/Residential

1. The minimum right of way width shall be 50 feet.
2. The minimum pavement width shall be 28 feet back to back of curb.
3. Curb and gutter is required.
4. A sidewalk with a minimum width of 5 feet is required on both sides of the road for local through streets. A sidewalk with a minimum width of 4 feet is required on both sides of the road in residential subdivisions.
5. A minimum 3'-0" buffer zone between the back of curb and the concrete sidewalk is required on both sides of the street.
6. At a minimum, cross section shall be in accordance with the typical street cross section detail included with these specifications.
7. The City of Bryant may require different traffic lane configurations if turn lanes are required by the City of Bryant. The City of Bryant may require additional pavement width to accommodate turn lanes.

G. Local 2

1. The minimum right of way width shall be 50 feet.
2. The minimum pavement width shall be 36 feet back to back of curb.
3. Bike lanes with a minimum width of 5' are required on both sides of the street.
4. Curb and gutter is required.
5. A sidewalk with a minimum width of 5 feet is required on both sides of the road for local through streets designated as Local 2.
5. A minimum 2'-0" buffer zone between the back of curb and the concrete sidewalk is required on both sides of the street.
6. At a minimum, cross section shall be in accordance with the typical street cross section detail included with these specifications.
7. The City of Bryant may require different traffic lane configurations if turn lanes are required by the City of Bryant. The City of Bryant may require additional pavement width to accommodate turn lanes.

PART 4.5 MINIMUM AND MAXIMUM GRADES

- A. The maximum grade for residential/local streets shall not exceed 12 percent.
- B. The minimum grade for streets shall not be less than 0.5 percent.

PART 4.6 SIGHT DISTANCE AND DESIGN SPEEDS

- A. Minimum sight distance for local/residential streets shall be 250 feet under ordinary conditions and 200 feet for hilly conditions. Collector streets shall have a minimum sight distance of 250-350 feet, depending upon topography.
- B. The design speed shall be 20-30 mph for local/residential streets.
- C. The design speed shall be 25-35 mph for collector streets.

PART 4.7 DEAD END STREETS/CUL-DE-SACS

- A. The maximum length for dead end streets/cul-de-sacs shall be 550 feet.

- B. Dead end streets/cul-de-sacs shall have a minimum turnaround right-of-way diameter of 100 feet.
- C. The minimum turnaround pavement street radius shall be 40 feet.

PART 4.8 PAVEMENT MARKINGS

- A. Pavement markings shall meet the requirements of the latest edition of AHTD standard specifications, MUTCD, AASHTO - A policy on Geometric Design of Highway and Streets, and AASHTO - Guide for the Development of Bicycle Facilities.
- B. Bike lanes shall be marked with the bike lane pavement marking logo in accordance with the typical detail included with these specifications.
- C. Pavement shall be striped and marked at the time of construction if required by City of Bryant.

PART 4.9 TRAFFIC SIGNS

- A. Traffic control devices shall meet the requirements of the Manual of Uniform Traffic Control Devices (MUTCD), latest edition. Developer shall obtain written approval from the City of Bryant Street Department and/or City of Bryant Public Works to utilize special or ornamental traffic signs within a subdivision. Maintenance of ornamental and/or special traffic signs shall be the responsibility of the Developer/Owner or Property Owners Association. Maintenance of ornamental or special traffic signs shall not be the responsibility of the City of Bryant.
- B. The location of all traffic control devices shall be at the discretion of the City of Bryant Street Department and/or City of Bryant Public Works. No sign shall be placed where any portion of the sign encroaches on the roadway or restricts handicapped accessibility.
- C. Traffic control devices shall be installed prior to occupancy of any residence, building or placing the street in service.
- D. The City of Bryant may require "No Parking" signs on one side of any street less than 30 feet wide face of curb to face of curb, or where vertical or horizontal alignment severely restricts sight distance.
- E. Traffic control devices within AHTD right-of-way shall meet the requirements of the latest edition of AHTD Standard Specifications and shall be approved by AHTD District 6 prior to installation.

PART 4.10 ALLEYS

- A. Alleys may be required at the rear of all lots to be used for business purposes, but shall not be provided in residential areas except where the Developer/Owner provides evidence satisfactory to the Development Review Committee and/or Planning Commission of the need for alleys.

PART 4.11 STREET LIGHTS

- A. Street lights shall be required on all streets as approved by the City of Bryant.
- B. Maximum spacing between street lights shall be 300 feet.
- C. Street lights including installation, materials, etc. shall be approved by the governing electric utility. All street lights that are not approved and maintained by governing electric utility shall be maintained by Developer/Owner or Property Owners Association, not by City of Bryant.

PART 4.12 ACCESS MANAGEMENT

- A. Access management shall be in accordance with the Master Street Plan.

SECTION 5

PAVEMENT DESIGN

PART 5.1 PAVEMENT TYPES

- A. Street pavement sections shall be flexible type with an asphalt concrete surface. Curb and gutter and sidewalks shall be Portland Cement Concrete.
- B. Flexible pavements shall consist of a crushed stone base course with a asphaltic concrete surface.
- C. Rigid type pavement structures consisting of a Portland Cement Concrete section and surface shall be used only with approval by the City of Bryant. Pavement design shall include full depth Portland Cement Concrete to the designed thickness with a crushed stone base course. Design thickness of concrete pavement and crushed stone base course shall be approved by the City of Bryant.

PART 5.2 PAVEMENT MATERIALS AND CONSTRUCTION

- A. All pavement materials, construction methods, standards, time and temperature constraints, seasonal constraints, and performance requirements shall be in accordance with the latest edition of the AHTD Standard Specifications for Highway Construction, and these specifications unless specifically approved otherwise in writing by the City of Bryant for a specific and individual exception.
- B. Mix designs shall meet the requirements of the latest edition of AHTD Standard Specifications.

PART 5.3 GEOTECHNICAL REQUIREMENTS

- A. Pavement design shall include a geotechnical investigation by a geotechnical engineer approved by the City of Bryant Street Department and/or City of Bryant Public Works. The geotechnical engineer shall test and assess the soils under all proposed streets and provide a report of all testing reports, soil classifications, subsurface drainage requirements, and pavement design recommendations to the City of City of Bryant Street Department and/or City of Bryant Public Works for review. The minimum sampling and testing frequency shall be one density test, one liquid limit, one plasticity index, and one gradation and soils classification for each 500 feet of street or section thereof with a minimum of three sets of tests per project. The minimum depth of boring or excavation for in-situ materials shall be four feet below the top of the elevation of the final compacted subgrade.
- B. Three copies of the geotechnical report, including one pdf format copy, shall be provided to the City of Bryant Street Department and/or City of Bryant Public Works along with the proposed street design drawings prior to starting construction on any road.
- C. For import material, the minimum sampling and testing frequency shall be one density test, one liquid limit, one plasticity index, and one gradation and soils classification.

PART 5.4 PAVEMENT DESIGN REQUIREMENTS

- A. Minor Arterial
 - 1. Asphalt (ACHM) pavement, base course and subgrade minimum requirements shall be as shown in the typical cross section detail in these specifications.
- B. Collector
 - 1. Asphalt (ACHM) pavement, base course and subgrade minimum requirements shall be as shown in the typical cross section detail in these specifications.

- C. Rural Collector
 - 1. Asphalt (ACHM) pavement, base course and subgrade minimum requirements shall be as shown in the typical cross section detail in these specifications.
- D. Industrial Collector
 - 1. Asphalt (ACHM) pavement, base course and subgrade minimum requirements shall be as shown in the typical cross section detail in these specifications.
- E. Local 1/Residential Streets
 - 1. Asphalt (ACHM) pavement, base course and subgrade minimum requirements shall be as shown in the typical cross section detail in these specifications.
- F. Local 2
 - 1. Asphalt (ACHM) pavement, base course and subgrade minimum requirements shall be as shown in the typical cross section detail in these specifications.
- G. Minimum rigid pavement (concrete) design thicknesses for all street classifications shall be as determined and recommended by the Geotechnical Investigation. Minimum rigid pavement thicknesses shall be approved by the City of Bryant Street Department, City of Bryant Public Works and/or Development Review Committee.
 - 1. Minimum concrete pavement thickness shall be 6-inches.
 - 2. Minimum base course thickness shall be the same as shown for asphalt on the typical cross section detail in these specifications .
 - 3. Concrete pavement shall be Portland Cement Concrete with a minimum 28-day compressive strength of 4,000 psi. Concrete shall be air-entrained with a maximum 4-inch slump.

PART 5.5 SUBGRADE MATERIAL

- A. Subgrade soils shall be all materials used for subgrade including in-situ materials and fill materials.
- B. Subgrades for pavement shall be stabilized by mechanical compaction. Stabilization methods such as fabrics and chemical stabilization may be submitted for approval when supported by engineering data and calculations to substantiate the adequacy of the stabilized procedure.
- C. Subgrade shall be compacted to 95 percent modified proctor density minimum. Moisture content shall be +/- 3% of optimum moisture unless otherwise supported by the site specific geotechnical data and approved by City of Bryant Public Works.
- D. Subgrade shall be prepared in such a manner that the base course shall be placed on a firm foundation that is stable and free from soft spots, pumping, dust pockets, wheel ruts, or other defects.
- E. The top 24 inches of the subgrade shall be a material not susceptible to frost action unless modified with cement, lime or another method approved specifically by the City of Bryant Public Works to resist frost action. Soils classified as A-4 and A-5 including sandy silts, fine silty sand or lean clays are highly susceptible to frost action.
- F. In-situ soils meeting the requirements outlined in these specifications may be utilized as subgrade material. In-situ soils used as subgrade shall be scarified to a minimum depth of 8-inches below finish subgrade, recompacted, and tested as described Section 8 of these specifications. Fill material for subgrade shall be placed in lifts not to exceed 8-inches compacted depth.
- G. Methods and procedures for establishing the total depth of soil replacement and/or modification shall be as specified by the design engineer and geotechnical investigations. The adequacy of in-situ soils and fill materials as pavement subgrade shall be evaluated based upon the soils classification, liquid

limit, and plasticity index.

- H. Soils with a liquid limit greater than 40, or a plasticity index greater than 15 shall be undercut and removed from the street section or improved by a design method of stabilization approved by City of Bryant Street Department and/or City of Bryant Public Works.
- I. Quality control testing shall be as specified in Section 8 of these specifications.

PART 5.6 BASE COURSE

- A. Base course material shall be crushed stone meeting the requirements of AHTD Class 7 aggregate base course as specified in the latest edition of AHTD Standard Specifications.
- B. Base course shall be compacted to 98 percent modified proctor density minimum. Moisture content shall be +/- 3% of optimum moisture.

PART 5.7 SURFACE COURSE

- A. Surface course for flexible pavement designs shall utilize plant mix bituminous base and binder courses conforming to AHTD Standard Specifications.
- B. Surface course for rigid pavement shall be Portland Cement Concrete as specified in the latest edition of AHTD Standard Specifications.

PART 5.8 CURB AND GUTTER

- A. Curb and gutter shall be Portland Cement Concrete with a minimum 28-day compressive strength of 4,000 psi. Concrete shall be air-entrained with a maximum 4-inch slump.
- B. Compaction requirements under curb and gutter shall conform to the requirements for street subgrade materials. Compaction requirements shall extend to a minimum of 1 foot behind the back of curb and gutter removing all soft spots and replacing with suitable material.
- C. Curb and gutter shall conform to the typical detail within these specifications or AHTD Standard Roadway Drawing Details for curbing.
- D. Expansion joints shall be made with 1/2-inch preformed expansion joint filler of a non-extruding type. Expansion joints shall be placed at intervals not exceeding 195 feet, intersection radii, driveways, stationary structures, and sidewalks.
- E. Contraction joints shall be sawed or formed at intervals not greater than 20 feet. Depth of saw-cut shall be 1 1/2-inch and have a width of 1/4-inch. Contraction joints shall be sealed in accordance with AHTD Standard Specifications.
- F. Forms shall be made of metal or wood and shall be properly braced. The minimum length of each section of form used shall be 10 feet. Each section of form shall be uniform and free from undesirable bends or warps. Forms shall be of such cross section and strength and so secured as to resist the pressure of the impact and vibration on any equipment which they support without springing or settlement.
- G. Curb and gutter placed with slip form or extruding equipment will be acceptable providing it complies with all of the above requirements.
- H. After curing, the curb shall be immediately backfilled to within 4 inches of the top curb to eliminate

the possibility of washing beneath the curb. The remaining 4 inches shall be topsoil.

- I. Cold weather protection shall meet the requirements of the latest edition of AHTD Standard Specifications.

PART 5.9 SUBSURFACE DRAINAGE

- A. Subsurface drainage shall be constructed where subsurface moisture will affect the stability of the subgrade and as recommended by the geotechnical investigations. Streets in cut sections and hillsides typically need subsurface drainage.

PART 5.10 ONE-HALF STREET IMPROVEMENTS

- A. When subdivisions, commercial developments, industrial developments, etc. are located on only one side of an existing street, one-half of the required right-of-way, from the center line of the existing right-of-way or from the centerline of the street whichever is greater, shall be provided. Right-of-way shall meet the minimum right-of-way requirements as stated in Section 4 of these specifications.
- B. When subdivisions, commercial developments, industrial developments, etc. are located on only one side of an existing street, one-half of the required street improvements, from the center line of the existing right-of-way or from the centerline of the street whichever is greater, shall be provided. Street improvements including asphalt or concrete paving, storm drainage, curb and gutter, sidewalks and other improvements shall be constructed in accordance with these specifications for that portion that adjoin existing streets.
- C. At a minimum, cross-section shall be in accordance with the typical street cross section details included with these specifications. Pavement reconstruction to the center line of the existing street shall be required when the existing street does not meet the requirements of these specifications.
- D. Geotechnical investigation requirements, for one-half street improvements, as stated in Section 5.3 may be waived by the City of Bryant.

SECTION 6

UTILITIES AND UTILITY CROSSINGS

PART 6.1 GENERAL

- A. The Developer/Owner shall be responsible for coordinating the installation of franchise utility lines and water, wastewater, and storm drain lines relative to street development.
- B. Design and installation of water, wastewater and storm drainage facilities shall conform to the current design criteria and related regulations for those facilities.
- C. All utilities shall be designed and installed in a manner that minimizes utilities under streets and curbs. All utilities crossing streets shall be near perpendicular to the street. Utilities located parallel to the street shall remain outside of the limits of the street section unless crossing perpendicular to the street. Utilities shall ensure that parallel utilities do not cross into the limits of the street around curves, corners or cul-de-sacs unless otherwise approved by the Public Works Department.
- D. All non-metallic buried facilities placed within public right-of-way either parallel to or crossing the roadway, shall have an approved identification wrap of detectable tape or wire in order that the facility can be located by metal locators or other suitable devices.
- E. All underground electrical lines within public right-of-way either parallel to or crossing the roadway shall include 3-inch minimum width underground detectable warning tape with red background and black letter stating, "CAUTION BURIED ELECTRIC LINE BELOW". This tape shall be detectable, durable, highly visible, resistant to elements, and meeting or exceeding all industry standards.
- F. All work within public right-of-way shall meet the requirements of these standards, Ordinance 2012-11, and all other applicable city ordinances, unless otherwise modified herein. All applicable permits shall be obtained by the Utility for any work taking place within public right-of-way.
- G. No new excavations or bores shall be allowed after 1:00pm on Fridays or on weekends.
- H. Permits - A permit shall be issued for a maximum of 1000 linear feet. Permits shall be valid for 6 months from the date of issuance. The contractor shall notify the Streets department locator at least five working days in advance of the anticipated start of construction. A permit shall not be issued to any company, contractor, or subcontractor that is not in good standing with the City; including, but not limited to, is under a stop work order or has unpaid fines or restitution to the City.
- I. Yard and Landscaping - All surfaces including lawns, pavements, sidewalks, curbs, berms, and other surfaces disturbed during the construction of this project shall be restored by the contractor to the original or better condition. All restoration, including lawns, pavements, sidewalks, curbs, berms, trees, and shrubs shall be warranted for a period of one year from the acceptance of restoration. It is the City's expectation that restoration shall be completed within no more than 15 days after the completion of construction.
- J. Trees - It is the intent that trees shall be preserved. The contractor will be responsible for any claim for damage to trees. Trees needing to be removed require the prior approval of the City.
- K. Private Utilities - Privately owned utilities may be located within the City-owned ROW and easements. These improvements include (but are not limited to) sanitary sewer laterals and water services. These private utilities are not located by the City of Bryant, it is the Contractor's responsibility to locate these utilities prior to work being done. The Contractor is responsible for any damage to private utilities and shall begin restoration immediately upon discovery.

- L. City Owned Utilities - Any damage to City Utilities shall be reported to the Bryant Public Works Department immediately. Bryant Public Works shall be reimbursed for any and all costs associated with repairing said damages.
- M. Stop Work Order - The Director of Public Works, the Director of Community Development or their designees has the authority to issue a stop work order. A stop work order will be issued in the following circumstances:
 - a. Working without a permit or with an expired permit.
 - b. Disruption of service of private utilities (including but not limited to water, sewer, gas, electrical, and communications) without immediate restoration.
 - c. Any violation of this ordinance.
 - d. Unsafe working conditions or unsafe site management.
- N. Fine - A five hundred (\$500) fine shall be imposed for any company, contractor or subcontractor working after a stop work order has been issued. For every subsequent violation, the fine shall be doubled the price of the previous fine. The Director of Public Works or the Director of Community Development has the authority to issue fines.

PART 6.2 FRANCHISED UTILITY LINES

- A. All franchised utility lines, which are underground, shall be installed in an encasement pipe under streets. The encasement pipe shall be installed by either the Developer/Owner or the utility before the subgrade is completed.
 - a. *Encasement Length* - The encasement length shall extend a minimum of six (6) feet beyond the back of curb or edge of pavement if no curb is present.
 - b. *Encasement Depth* - The minimum depth of cover for encasement pipe shall be thirty-six (36) inches measured from the top of the encasement pipe to the top of the subgrade or forty-eight (48) inches measured from the top of encasement pipe to the top of pavement, whichever provides the greatest depth.

PART 6.3 WATER, WASTEWATER, AND STORM DRAIN LINES

- A. Water, wastewater, and storm drain lines shall be installed before the subgrade is complete.

PART 6.4 BORING AND JACKING

- A. All street, alley, sidewalk, road, highway or other public way, or curb and gutter crossings by utilities and other parties shall be required to be bored unless an open cut is approved by the City Engineering Department or Public Works Department. Open cut approvals shall not be withheld unreasonably and if required, shall meet the requirements of Section 6.5 or Section 6.6.
- B. The depth of bury on installations which are jacked or bored under any street shall have a minimum depth of bury of thirty-six (36) inches measured from the top of the pipe or casing to the top of the subgrade or forty-eight (48) inches measured from the top of pipe or casing to the top of pavement, whichever provides the greatest depth. In the case of a street section with a ditch section, the bury shall be a minimum of twenty-four (24) inches below flow line, but still a minimum of the above referenced depth below street section, whichever is greater. If the pavement or curb and gutter structure is damaged by the jacking or boring installation, it shall be repaired in a manner approved by the City Engineering Department or Public Works Department.
- C. Prior to any directional drilling operation, the contractor shall Pothole any utility mainline, service line, or storm drain that crosses the planned drill path. Pothole depth shall go to the planned drill path's depth even if that depth is beyond the deepest known utility line. At pothole locations, the contractor shall visually observe the drill stem and drill head during drilling to ensure the directional drilling machine operator avoids striking utility lines or storm drains along the drill path. Additionally, the contractor shall pothole at 100 foot intervals along the planned drill path to ensure proper alignment and grade are maintained.

PART 6.5 PAVEMENT CUTS- EXISTING STREETS

- A. Pavement cuts for drainage and/or utility lines under existing streets shall be repaired in accordance with the typical detail included in these specifications.
- B. Backfill material shall meet the requirements of AHTD Class 7 aggregate base course as specified in the latest edition of AHTD Standard Specifications.
- C. Backfill material shall be compacted to 98 percent modified proctor density minimum. Backfill material shall be compacted in maximum 12 inch lifts.

PART 6.6 DRAINAGE AND/OR UTILITY CUT BACKFILL ON STREET UNDER CONSTRUCTION

- A. Trench backfill for storm drains and/or utility lines for all trenches excavated in areas to be paved shall be in accordance with the typical detail included in these specifications.
- B. Backfill material shall meet the requirements of AHTD Class 7 aggregate base course as specified in the latest edition of AHTD Standard Specifications.
- C. Backfill material shall be compacted to 98 percent modified proctor density minimum. Backfill material shall be compacted in maximum 12 inch lifts.

SECTION 7

STORM DRAINAGE AND DRAINAGE FACILITIES

PART 7.1 GENERAL

- A. Design of storm drains and drainage facilities shall be by a licensed professional engineer in accordance with the City of Bryant Storm Water Management Manual.
- B. All drainage structures for transporting of storm water located under the pavement shall be reinforced concrete pipe or reinforced concrete culvert.
- C. Precast box culverts shall be certified for H-20 loading when under streets.
- D. Pipes and culverts shall have smooth flow lines with no depressions and no indentations or protrusions into the interior.
- E. Corrugated pipes shall be connected with bands supplied by the manufacturer.
- F. Lift holes shall be filled with non-shrink grout.

PART 7.2 STORM DRAIN MATERIALS

- A. Storm drain pipe materials shall meet the requirements the City of Bryant Storm Water Management Manual and these specifications.
- B. Reinforced concrete pipe shall be used for all storm drains and facilities under streets.
- C. Plastic, HDPE, Polyvinyl Chloride (PVC), or polymer coated corrugated metal pipe with a minimum 10 mil polymer coating both inside and out shall be permitted alongside (parallel to) streets. These shall not be permitted under streets.

PART 7.3 BEDDING MATERIAL

- A. Bedding material for reinforced concrete pipe and corrugated metal shall be in accordance with the manufacturer's recommendations.
- B. Bedding material for HDPE, plastic, and PVC shall be granular bedding material. Bedding material shall extend to 6 inches above the top of the pipe.

PART 7.4 DROP INLETS AND JUNCTION BOXES

- A. Junction boxes and drop inlets shall meet the requirements of the City of Bryant Storm Water Management Manual and the latest edition of AHTD Standard Specifications.
- B. Concrete shall be Portland Cement Concrete with a minimum 28-day compressive strength of 4,000 psi.
- C. All pipe entering and leaving the structure shall be cut flush with the inside face and grouted around the perimeter as necessary.
- D. All concrete surfaces shall be free of honeycomb and cracks.

PART 7.5 BRIDGES

- A. Bridges shall meet the requirements of the City of Bryant Storm Water Management Manual and the latest edition of the AHTD Standard Specifications.

SECTION 8

QUALITY CONTROL TESTING AND INSPECTIONS

PART 8.1 GENERAL

- A. Materials and construction employed in street improvements shall be subject to inspection and quality control testing. All testing of materials and construction shall be provided and paid for by the Developer/Owner.
- B. The Developer/Owner shall provide for inspections of street improvements during construction. The inspections shall be accomplished under the supervision of the Engineer of Record. The Engineer of Record shall provide certification that all materials and construction conform to the approved plans and specifications and with these minimum street standards.
- C. The Engineer of Record shall furnish inspection whenever a critical construction activity is taking place. This means that a representative of the Engineer of Record must be on-site whenever a critical construction activity is taking place.
- D. All field tests required for a project shall be witnessed by the City of Bryant, Engineer of Record, contractor, or their authorized representatives.
- E. The City of Bryant Street Department and/or City of Bryant Public Works shall be notified at least one day in advance of any test(s). It is the responsibility of the contractor to coordinate the scheduling of all tests with the City.

PART 8.2 QUALITY CONTROL TESTING

- A. All testing shall be accomplished by a testing firm approved by the City of Bryant Street Department and/or City of Bryant Public Works and shall be performed under the supervision of a licensed Professional Engineer.
- B. Sampling and testing locations shall be subject to approval by the City of Bryant Street Department and/or City of Bryant Public Works.
- C. Density tests on subgrades and base course shall be taken every 300 feet or portion thereof, except that each cul-de-sac street shall have a minimum of two tests taken regardless of its length. Compaction shall be in accordance with Section 5 of these specifications.
- D. Base course shall not be more than 1/4-inch less than specified thickness.
- E. The City of Bryant reserves the right to require core sampling on asphalt streets. If required, asphalt streets shall be cored every 300 feet or portion thereof for the purpose of checking density and thickness, except that each cul-de-sac street shall have a minimum of two cores taken regardless of length, with one core being taken in the cul-de-sac. The location of the core shall be chosen by the City of Bryant Street Department and/or City of Bryant Public Works so as to accurately represent the quality of the asphalt laid in a particular area. Core samples shall be used to indicate asphalt thickness, and in no case shall be more than 1/4-inch less than specified thickness. For cores that indicate thickness 1/4-inch to 1/2-inch less than that specified, "isolation" cores shall be required. To "isolate", the contractor, at no expense to the City of Bryant, shall cut cores 10 feet either side of the initial core. If one or both of the cores are in the acceptable tolerance, the section will be accepted. If one or both cores fail, then additional cores shall be cut 25 feet away from the initial core in the failing directions. Subsequent cores shall be cut at 50 ft. intervals in the direction of failure until a core that passes tolerance is obtained. The isolated area shall be that which falls within the limits of acceptable

thickness. The areas that fall within the 1/4-inch to 1/2-inch less than specified thickness shall be removed and replaced or warranted for five years at 150% of construction cost based on the estimate provided by the Engineer of Record. Areas that are determined to exceed the 1/2-inch less than specified thickness shall be removed and replaced within the limits of the acceptable thickness determined by the isolation method. Core holes shall be filled with non-shrink grout flush with final surface within 24 hours of test.

- F. The City of Bryant reserves the right to require core sampling on concrete streets. If required, concrete streets shall be cored every 300 feet or portion thereof for the purpose of checking thickness, except that each cul-de-sac street shall have a minimum of two cores taken regardless of length, with one core being taken in the cul-de-sac. The location of the core shall be chosen by the City of Bryant Street Department and/or City of Bryant Public Works so as to accurately represent the quality of the asphalt laid in a particular area. Core samples shall be used to indicate thickness. Thickness shall not be more than 0.50-inches less than specified thickness. Core holes shall be filled with non-shrink grout flush with final surface within 24 hours of test.
- G. For concrete streets, one set of cylinders shall be taken at the beginning of every pour then for every 1,000 linear feet of streets or portion thereof. Concrete testing out less than 85% of design strength shall be removed and replaced. For concrete falling between 85% and 100% of design strength, an extended five year warranty shall be provided at 150% of construction costs based on an estimate provided by the Engineer of Record.

PART 8.3 SUBGRADE

- A. After the subgrade is prepared in accordance with these specifications, a wheel proof-roll test is to be completed by the Contractor/Developer/Owner. Using a loaded dump truck (62,000 lb), drive over the surface looking for any movement, pumping, rutting, or tracking. All soft spots and areas that are pumping shall be removed and backfilled with AHTD Class 7 base course material or other material approved by the City of Bryant Street Department and/or City of Bryant Public Works in accordance with these specifications and the latest edition of AHTD standard specifications.
- B. After the Contractor/Developer/Owner has completed the wheel proof-roll test and finds the subgrade to be stable, then and only then, is the City of Bryant Street Department and/or City of Bryant Public Works to be notified to conduct a final wheel proof-roll test.
- C. A representative of the City of Bryant Street Department and/or City of Bryant Public Works shall complete a proof-roll test with a rubber-tired loaded dump truck weighing a minimum of 62,000 lbs. after the subgrade has been prepared and tested by the Contractor/Developer/Owner. If the subgrade fails the proof-roll test and a representative of the City of Bryant has to perform another test, there will be a \$200.00 fee for each additional proof-roll test.
- D. Density tests are required in accordance with the latest edition of AHTD standard specifications. The City of Bryant Street Department and/or City of Bryant Public Works shall be notified at least one day in advance of any density test(s). A representative of the City of Bryant Street Department and/or City of Bryant Public Works shall be on-site to witness the test(s) unless instructed otherwise. Copies of all test results shall be sent to the City of Bryant Public Works.
- E. The subgrade shall meet all of the requirements of these specifications prior to base course being placed.
- F. If the succeeding base course is not placed immediately after the subgrade has been prepared and it becomes rutted, rough or unstable, the subgrade shall be shaped and re-compacted in accordance with these specifications and the latest edition of AHTD standard specifications.

PART 8.4 BASE COURSE

- A. After the base course is prepared in accordance with these specifications, a wheel proof-roll test is to be completed by the Contractor/Developer/Owner. Using a loaded dump truck (62,000 lb), drive over the surface looking for any movement, pumping, rutting, or tracking. All soft spots and areas that are pumping shall be removed and backfilled with AHTD Class 7 base course material or other material approved by the City of Bryant Street Department and/or City of Bryant Public Works in accordance with these specifications and the latest edition of AHTD standard specifications.
- B. After the Contractor/Developer/Owner has completed the wheel proof-roll test and finds the base course to be stable, then and only then, is the City of Bryant Street Department and/or City of Bryant Public Works to be notified to conduct a final wheel proof-roll test.
- C. A representative of the City of Bryant Street Department and/or City of Bryant Public Works shall complete a proof-roll test with a rubber-tired loaded dump truck weighing a minimum of 62,000 lbs. after the base course has been prepared and tested by the contractor. If the base course fails the proof-roll test and a representative of the City of Bryant has to perform another test, there will be a \$200.00 fee for each additional proof-roll test.
- D. Density tests are required in accordance with the latest edition of AHTD standard specifications. The City of Bryant Street Department and/or City of Bryant Public Works shall be notified at least one day in advance of any density test(s). A representative of the City of Bryant Street Department and/or City of Bryant Public Works shall be on-site to witness the test(s) unless instructed otherwise. Copies of all test results shall be sent to the City of Bryant Public Works.
- E. The base course shall meet all of the requirements of these specifications prior to asphalt being placed.
- F. If the succeeding courses of asphalt are not placed immediately after the base course has been prepared and it becomes rutted, rough or unstable, the base course shall be shaped and re-compacted in accordance with these specifications and the latest edition of AHTD standard specifications.

SECTION 9

EROSION CONTROL

PART 9.1 GENERAL

- A. Erosion control shall meet the requirements of the City of Bryant Storm Water Management Manual and the Arkansas Department of Environmental Quality.

PART 9.2 PERMITS REQUIRED

- A. Contractor shall obtain permits, if required, from the Arkansas Department of Environmental Quality and Corps of Engineers. Permits that may be required include, but not limited to, ADEQ short term activity authorization, ADEQ Storm Water, and Corps of Engineers.

SECTION 10

SIDEWALKS

PART 10.1 GENERAL

- A. Sidewalks shall be Portland Cement Concrete with a minimum 28-day compressive strength of 4,000 psi.
- B. Sidewalks shall be on both sides of streets in line with sidewalks on opposite corners of roads.
- C. All sidewalks including ramps shall meet all current Federal Americans with Disabilities (ADA) design guidelines or requirements.
- D. Traverse slopes shall not exceed 2 percent.
- E. Subgrade under sidewalks shall be compacted to 90 percent modified proctor density minimum.
- F. Sidewalks shall not be placed upon grassy or organic materials.
- G. Sidewalks which extend or link existing sidewalks shall adjoin the existing sidewalks to form a continuous, even pathway.
- H. Utility poles, utility boxes, mailboxes, fire hydrants, and other similar obstructions shall not be located in sidewalks. Sidewalk location may vary at the discretion of the City of Bryant to avoid such obstacles.

PART 10.2 MINIMUM THICKNESS AND REINFORCEMENT

- A. Sidewalks shall have a minimum thickness of 4 inches.
- B. Sidewalks shall be reinforced, at a minimum, with woven wire fabric reinforcement.

PART 10.3 MINIMUM WIDTH

- A. Minimum width shall be 4 feet for residential streets and 5 feet for local 1, local 2, collector, and arterial streets.

PART 10.4 CONTRACTION AND EXPANSION JOINTS

- A. Contraction joints shall be provided perpendicular to the sidewalk at intervals equal to the sidewalk width.
- B. Expansion joints shall be constructed perpendicular to the sidewalk at intervals equal to five times the sidewalk width. Expansion joints shall be made with 1/2-inch preformed expansion joint filler of a non-extruding type. Expansion joints shall be placed at driveways, drop inlets, and curbs.

PART 10.5 QUALITY CONTROL TESTING AND INSPECTION BY CITY OF BRYANT

- A. Subgrade and formwork for sidewalks shall be inspected by the City of Bryant prior to pouring of the sidewalk.
- B. All testing of materials and construction shall be provided and paid for by the Developer/Owner.

- C. All field tests required for a project shall be witnessed by the City of Bryant, contractor, or their authorized representatives.
- D. All testing shall be accomplished by a testing firm approved by the City of Bryant Street Department and/or City of Bryant Public Works and shall be performed under the supervision of a licensed Professional Engineer.
- E. Sampling and testing locations shall be subject to approval by the City of Bryant Street Department and/or City of Bryant Public Works.
- F. Density tests on subgrades shall be taken every 300 feet or portion thereof. Compaction shall be in accordance with Section 5 of these specifications.
- G. The City of Bryant Street Department and/or City of Bryant Public Works shall be notified at least one day in advance of the need to inspect subgrade and formwork of sidewalks.

APPENDIX A
STANDARD DETAILS

A1

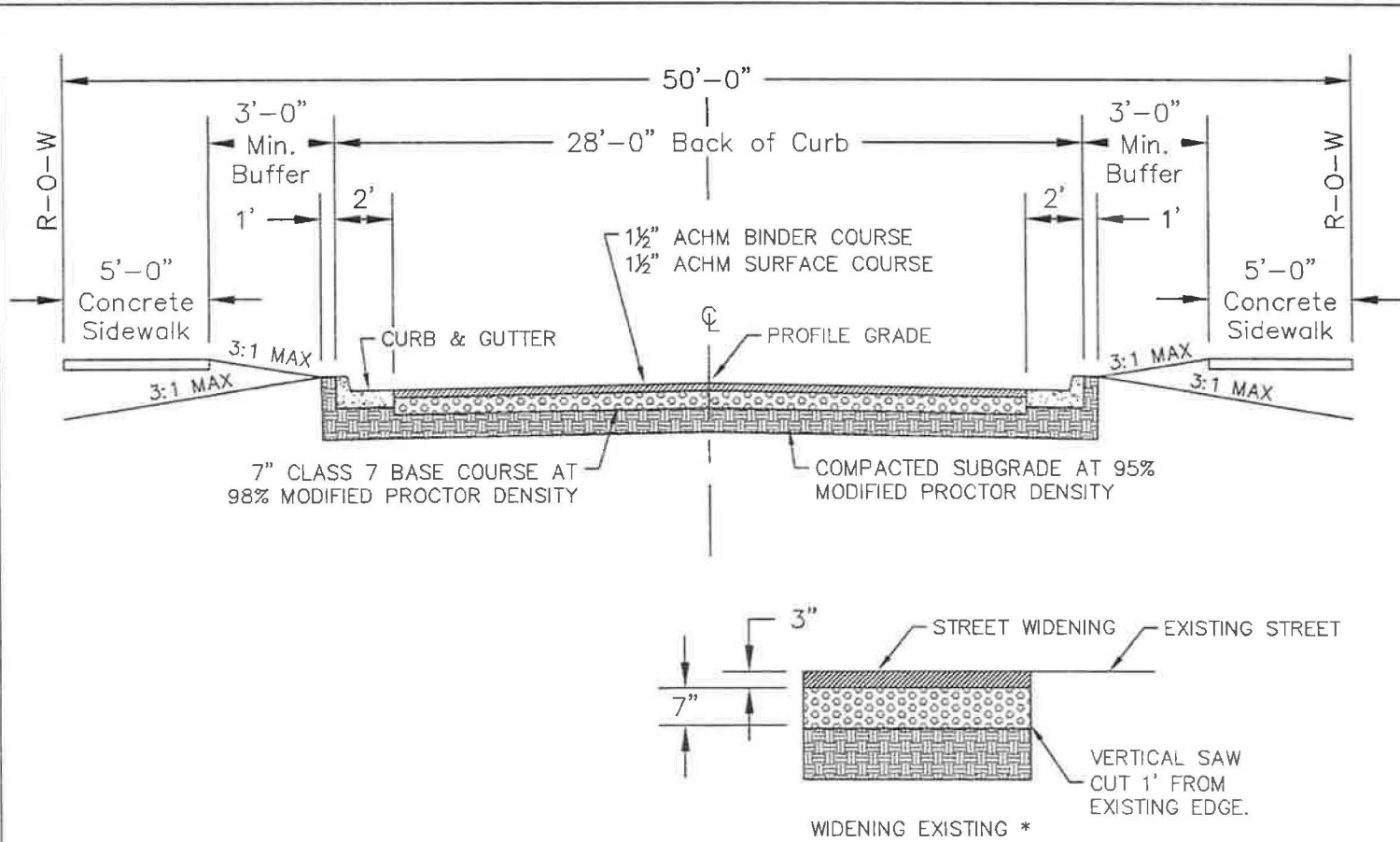

CITY OF BRYANT

TYPICAL SECTION
LOCAL 1 / RESIDENTIAL
STREET

DETAIL 1

Issue Date	Revision Date
APRIL 2013	

- GENERAL NOTES
1. IN AREAS TO RECEIVE BITUMINOUS PAVING, CONCRETE DRIVEWAYS OR CURB AND GUTTER, SUBGRADE SHALL BE COMPACTED TO A DENSITY NOT LESS THAN 95% OF MAXIMUM MODIFIED DENSITY OBTAINED AT OPTIMUM MOISTURE CONTENT.
 2. FOR AREAS OF SUBGRADE PREPARATION TO RECEIVE CONCRETE SIDEWALKS, SUBGRADE SHALL BE COMPACTED TO DENSITY OF 90% MAXIMUM MODIFIED DENSITY.
 3. CRUSHED STONE - MATERIAL IN EACH COURSE SHALL BE COMPACTED TO A DENSITY OF 98% MAXIMUM MODIFIED DENSITY.
 4. CONCRETE SIDEWALK SHALL BE A MINIMUM OF 4' WIDE IN RESIDENTIAL SUBDIVISIONS

* NOTES: PAVEMENT RECONSTRUCTION TO CENTERLINE IS REQUIRED WHEN EXISTING STREET DOES NOT MEET THESE STANDARDS.

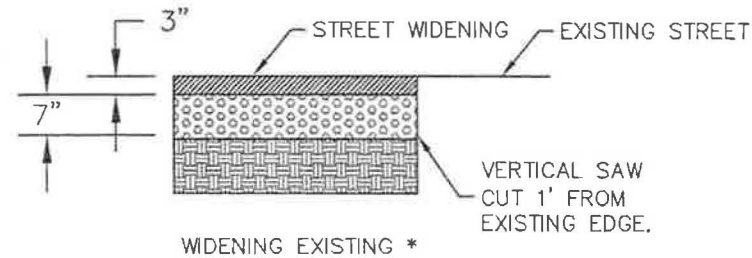
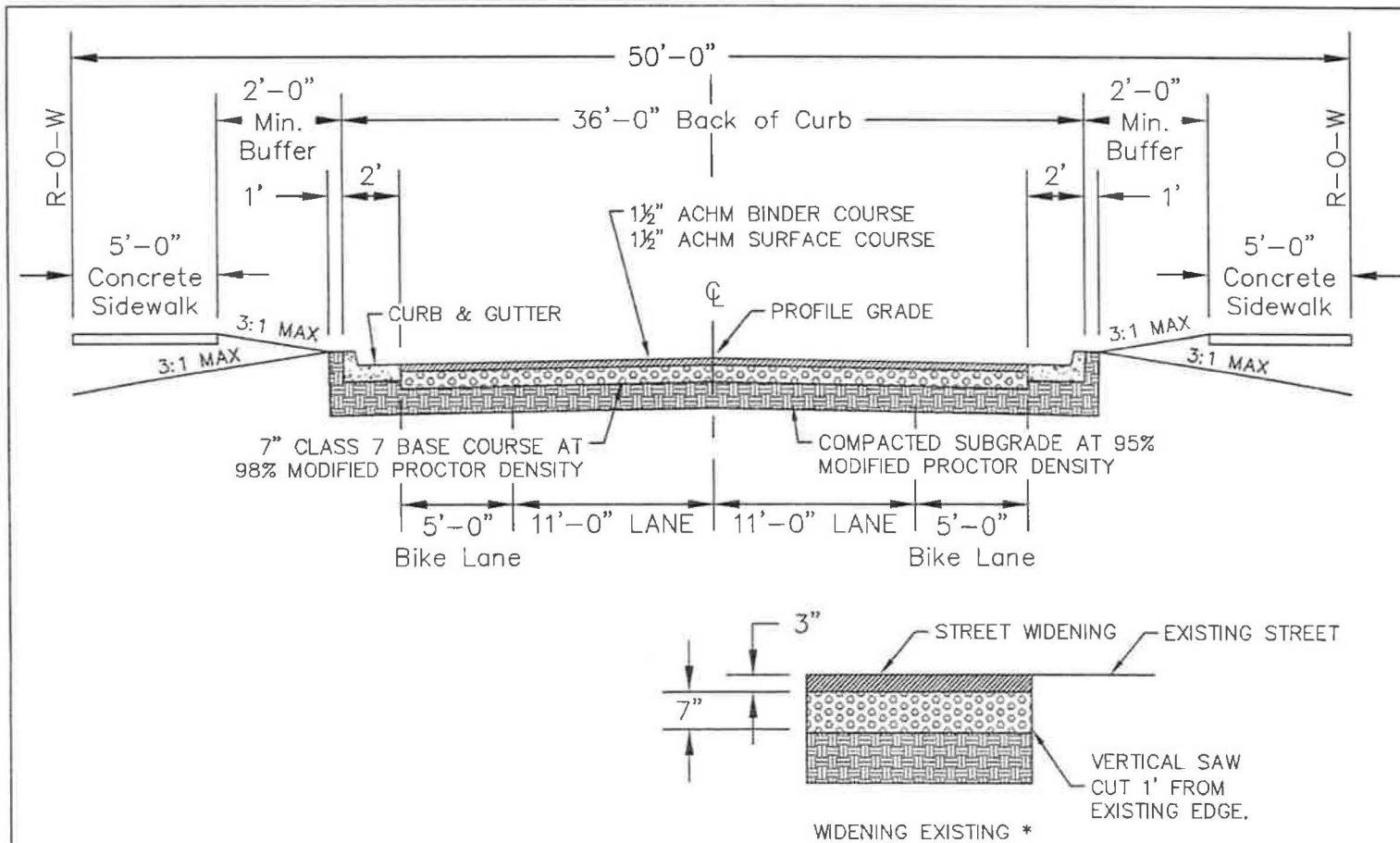

GENERAL NOTES

1. IN AREAS TO RECEIVE BITUMINOUS PAVING, CONCRETE DRIVEWAYS OR CURB AND GUTTER, SUBGRADE SHALL BE COMPACTED TO A DENSITY NOT LESS THAN 95% OF MAXIMUM MODIFIED DENSITY OBTAINED AT OPTIMUM MOISTURE CONTENT.
2. FOR AREAS OF SUBGRADE PREPARATION TO RECEIVE CONCRETE SIDEWALKS, SUBGRADE SHALL BE COMPACTED TO DENSITY OF 90% MAXIMUM MODIFIED DENSITY.
3. CRUSHED STONE - MATERIAL IN EACH COURSE SHALL BE COMPACTED TO A DENSITY OF 98% MAXIMUM MODIFIED DENSITY.

* NOTES: PAVEMENT RECONSTRUCTION TO CENTERLINE IS REQUIRED WHEN EXISTING STREET DOES NOT MEET THESE STANDARDS.

CITY OF BRYANT

TYPICAL SECTION
LOCAL 2
STREET

DETAIL 2

Issue Date	Revision Date
APRIL 2013	

A3

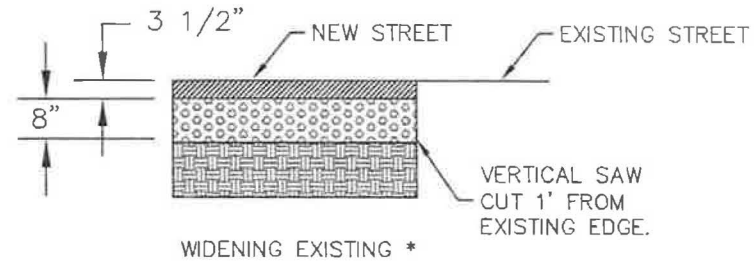
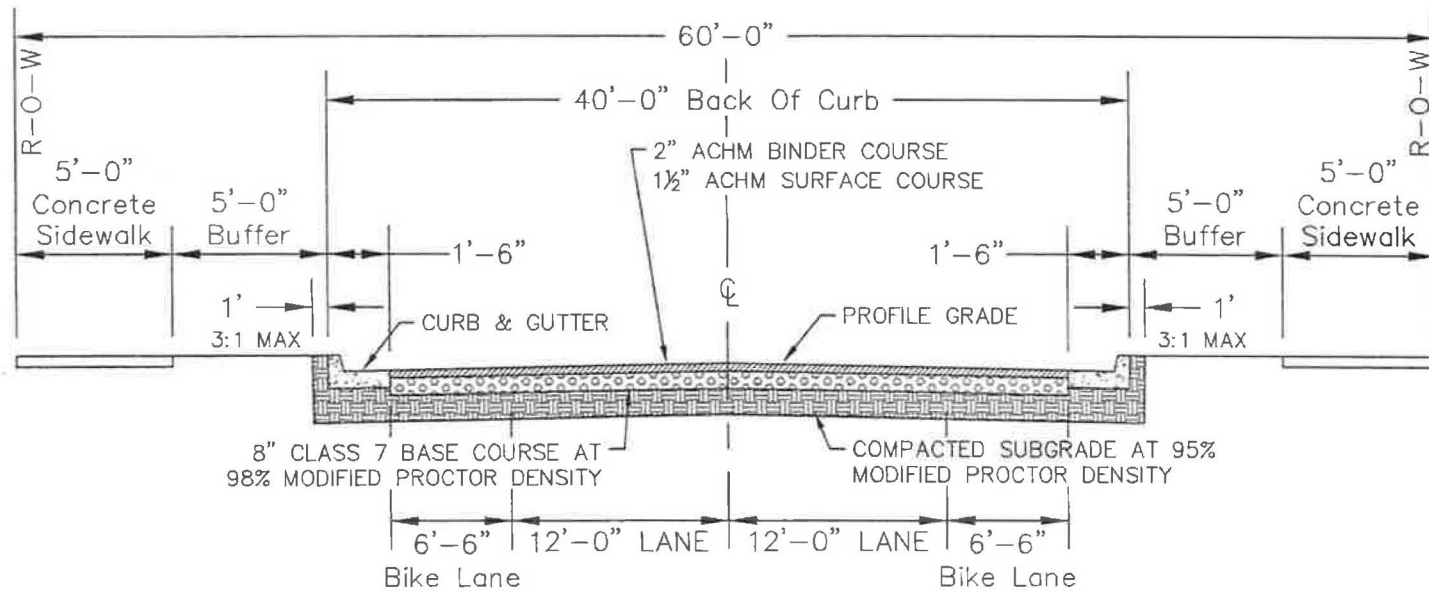

GENERAL NOTES

1. IN AREAS TO RECEIVE BITUMINOUS PAVING, CONCRETE DRIVEWAYS OR CURB AND GUTTER, SUBGRADE SHALL BE COMPACTED TO A DENSITY NOT LESS THAN 95% OF MAXIMUM MODIFIED DENSITY OBTAINED AT OPTIMUM MOISTURE CONTENT.
2. FOR AREAS OF SUBGRADE PREPARATION TO RECEIVE CONCRETE SIDEWALKS, SUBGRADE SHALL BE COMPACTED TO DENSITY OF 90% MAXIMUM MODIFIED DENSITY.
3. CRUSHED STONE - MATERIAL IN EACH COURSE SHALL BE COMPACTED TO A DENSITY OF 98% MAXIMUM MODIFIED DENSITY.

* NOTES: PAVEMENT RECONSTRUCTION TO CENTERLINE IS REQUIRED WHEN EXISTING STREET DOES NOT MEET THESE STANDARDS.

CITY OF BRYANT

TYPICAL SECTION
COLLECTOR STREET

DETAIL 3

Issue Date
APRIL 2013

Revision Date

A4

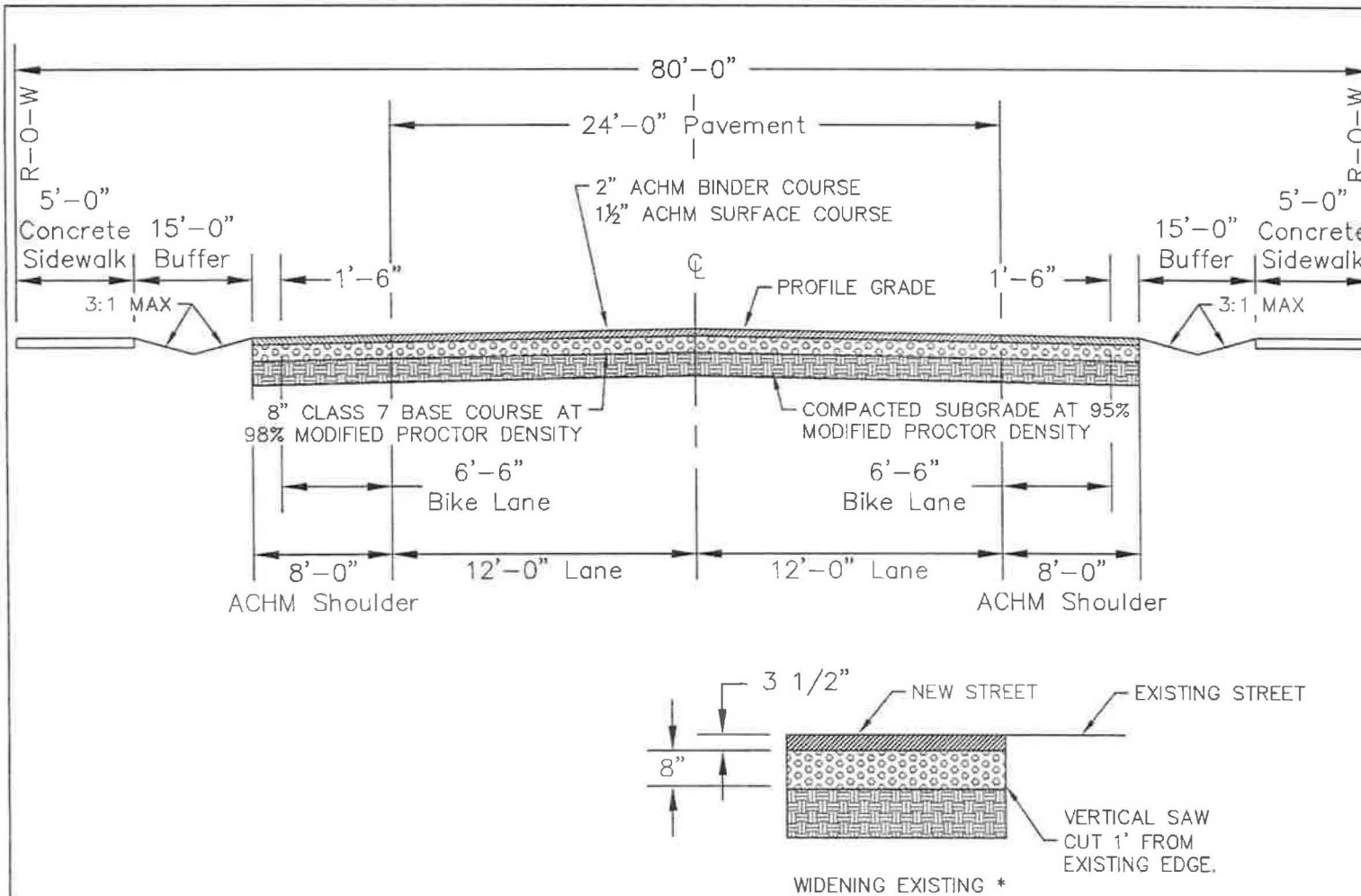

WIDENING EXISTING *

GENERAL NOTES

1. IN AREAS TO RECEIVE BITUMINOUS PAVING, CONCRETE DRIVEWAYS OR CURB AND GUTTER, SUBGRADE SHALL BE COMPACTED TO A DENSITY NOT LESS THAN 95% OF MAXIMUM MODIFIED DENSITY OBTAINED AT OPTIMUM MOISTURE CONTENT.
2. FOR AREAS OF SUBGRADE PREPARATION TO RECEIVE CONCRETE SIDEWALKS, SUBGRADE SHALL BE COMPACTED TO DENSITY OF 90% MAXIMUM MODIFIED DENSITY.
3. CRUSHED STONE - MATERIAL IN EACH COURSE SHALL BE COMPACTED TO A DENSITY OF 98% MAXIMUM MODIFIED DENSITY.

* NOTES: PAVEMENT RECONSTRUCTION TO CENTERLINE IS REQUIRED WHEN EXISTING STREET DOES NOT MEET THESE STANDARDS.

CITY OF BRYANT

TYPICAL SECTION
RURAL COLLECTOR
STREET

DETAIL 4

Issue Date	Revision Date
APRIL 2013	

A5

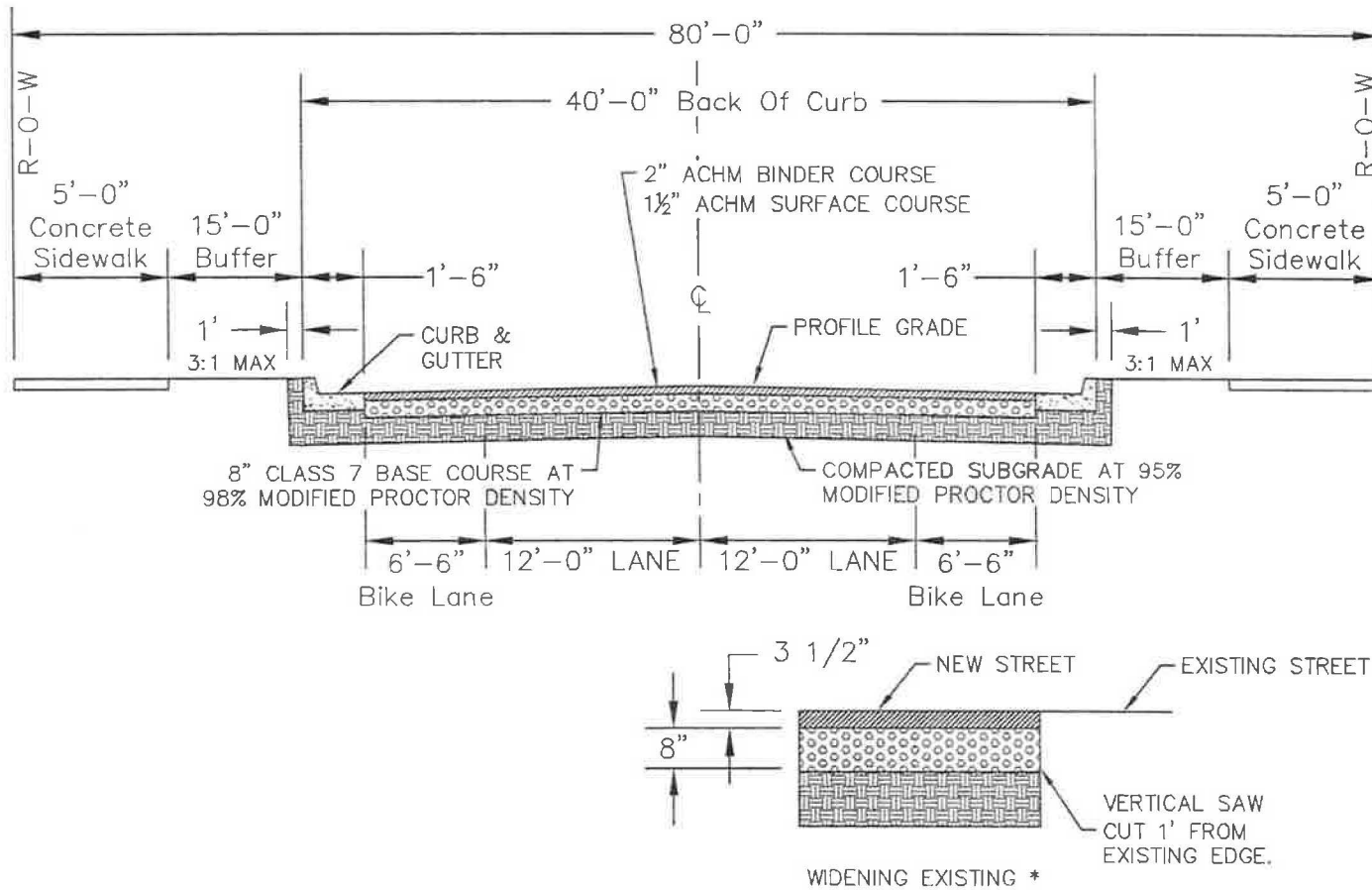

- GENERAL NOTES
1. IN AREAS TO RECEIVE BITUMINOUS PAVING, CONCRETE DRIVEWAYS OR CURB AND GUTTER, SUBGRADE SHALL BE COMPACTED TO A DENSITY NOT LESS THAN 95% OF MAXIMUM MODIFIED DENSITY OBTAINED AT OPTIMUM MOISTURE CONTENT.
 2. FOR AREAS OF SUBGRADE PREPARATION TO RECEIVE CONCRETE SIDEWALKS, SUBGRADE SHALL BE COMPACTED TO DENSITY OF 90% MAXIMUM MODIFIED DENSITY.
 3. CRUSHED STONE – MATERIAL IN EACH COURSE SHALL BE COMPACTED TO A DENSITY OF 98% MAXIMUM MODIFIED DENSITY.

* NOTES: PAVEMENT RECONSTRUCTION TO CENTERLINE IS REQUIRED WHEN EXISTING STREET DOES NOT MEET THESE STANDARDS.

CITY OF BRYANT

TYPICAL SECTION
INDUSTRIAL
COLLECTOR STREET

DETAIL 5

Issue Date	Revision Date
APRIL 2013	

A6

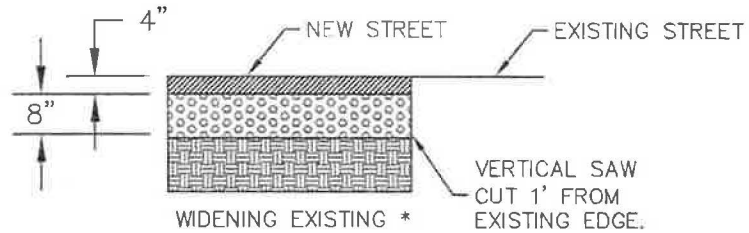
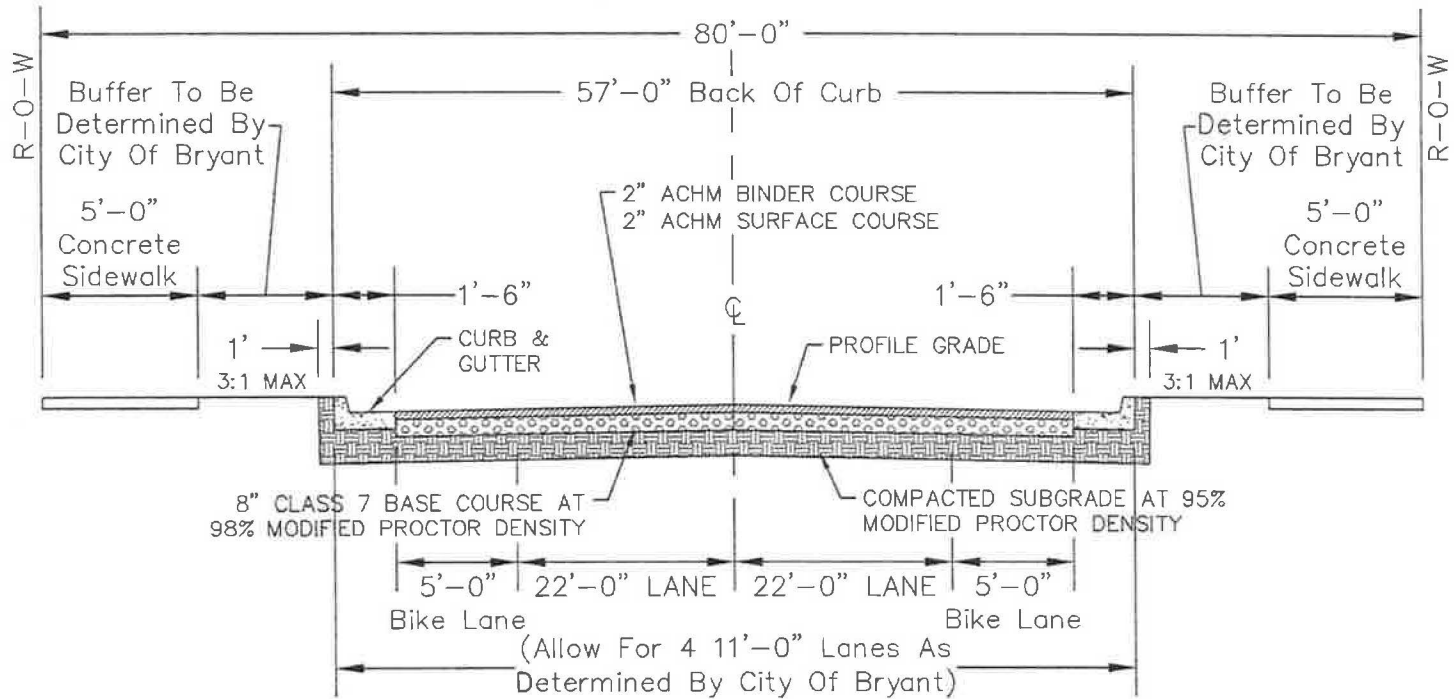

GENERAL NOTES

1. IN AREAS TO RECEIVE BITUMINOUS PAVING, CONCRETE DRIVEWAYS OR CURB AND GUTTER, SUBGRADE SHALL BE COMPACTED TO A DENSITY NOT LESS THAN 95% OF MAXIMUM MODIFIED DENSITY OBTAINED AT OPTIMUM MOISTURE CONTENT.
2. FOR AREAS OF SUBGRADE PREPARATION TO RECEIVE CONCRETE SIDEWALKS, SUBGRADE SHALL BE COMPACTED TO DENSITY OF 90% MAXIMUM MODIFIED DENSITY.
3. CRUSHED STONE – MATERIAL IN EACH COURSE SHALL BE COMPACTED TO A DENSITY OF 98% MAXIMUM MODIFIED DENSITY.

* NOTES: PAVEMENT RECONSTRUCTION TO CENTERLINE IS REQUIRED WHEN EXISTING STREET DOES NOT MEET THESE STANDARDS.

CITY OF BRYANT

TYPICAL SECTION
MINOR ARTERIAL

DETAIL 6

Issue Date
APRIL 2013

Revision Date

CITY OF BRYANT

CURB & GUTTER
SECTIONS

Issue Date
APRIL 2013

Revision Date

DETAIL 7

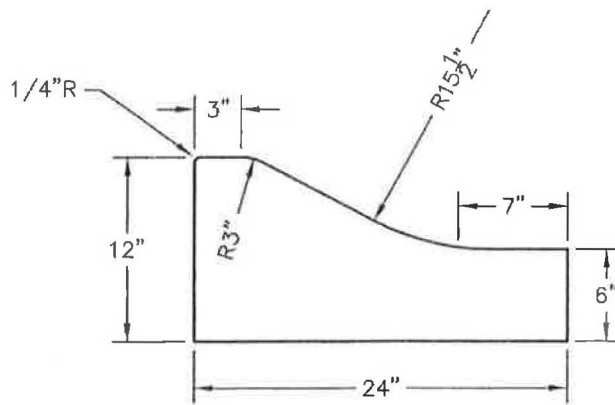
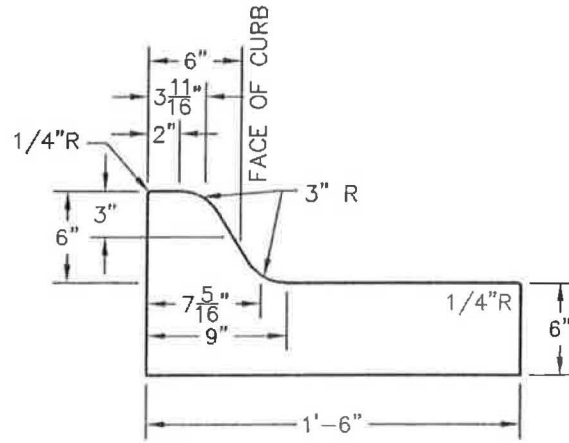

CITY OF BRYANT	TYPICAL SECTION DRAINAGE AND UTILITY CUT BACKFILL ON STREET UNDER CONSTRUCTION	Issue Date APRIL 2013	Revision Date
		DETAIL 8	

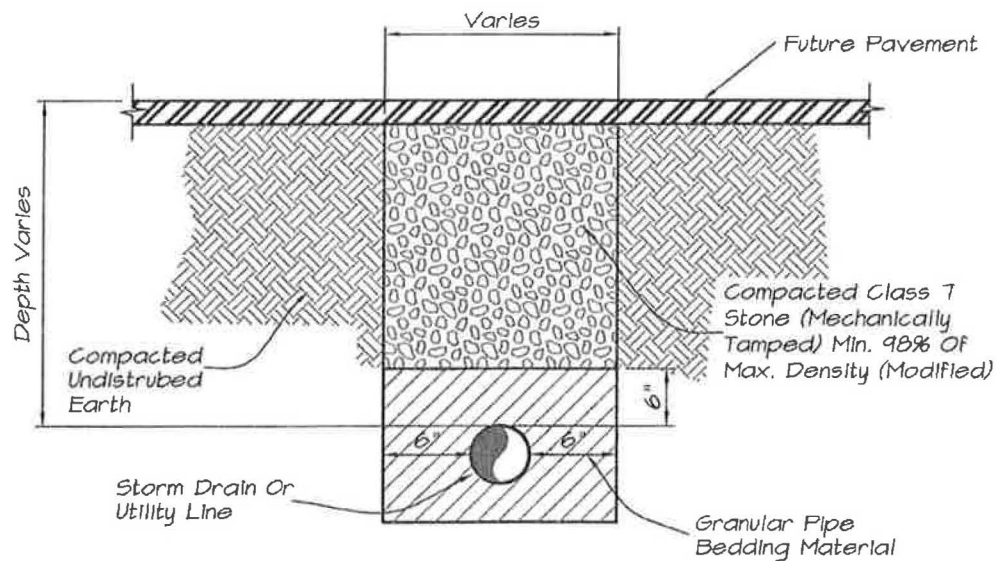

*Note: This Backfill Procedure Shall Be Utilized For
All Trenches Excavated In Area To Be Paved*

CITY OF BRYANT

TYPICAL SECTION
ASPHALT PAVEMENT
REPAIR ON
EXISTING STREET

Issue Date
APRIL 2013

Revision Date

DETAIL 9

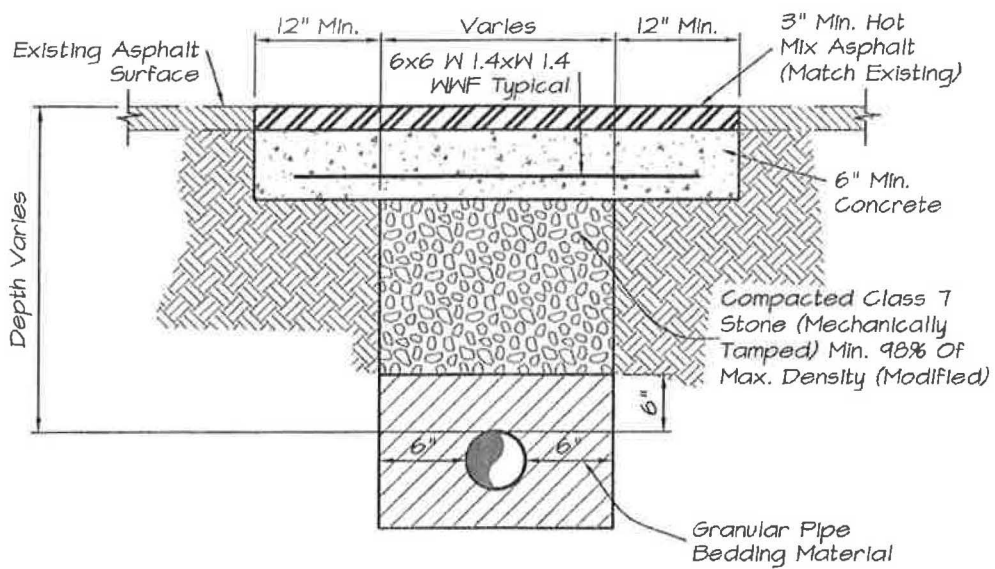

CITY OF BRYANT

TYPICAL SECTION
CONCRETE PAVEMENT
REPAIR ON EXISTING
STREET

Issue Date
APRIL 2013

Revision Date

DETAIL 10

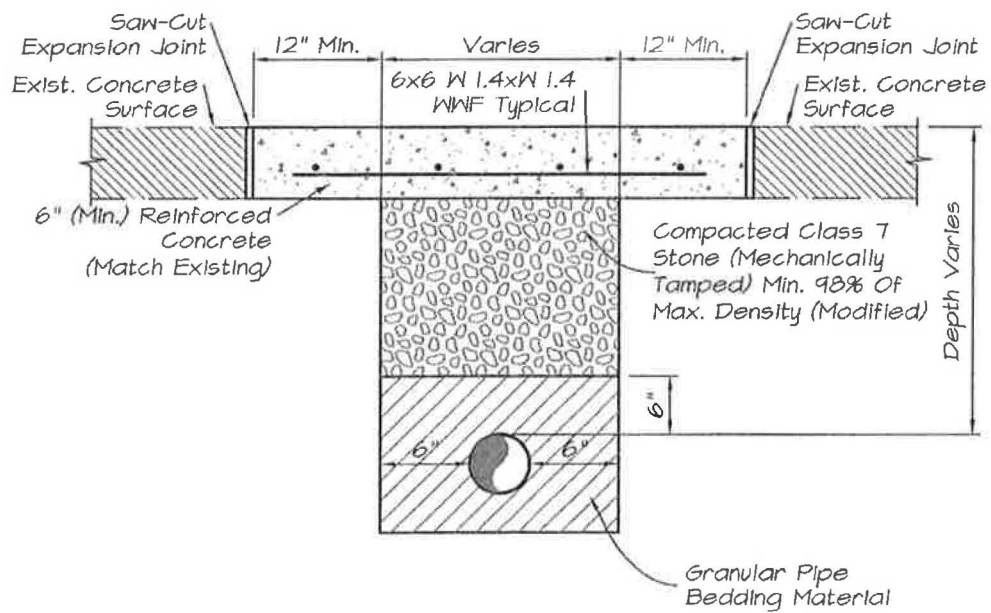

A10

CITY OF BRYANT	BIKE LANE PAVEMENT MARKING	Issue Date APRIL 2013	Revision Date
		DETAIL 11	



A11